

Installation instructions

安装说明书

Suitable for use with similar products / 适于用同类产品

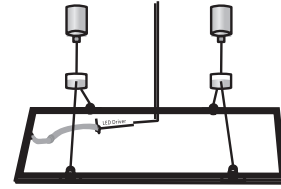

Panel lights / 面板灯

Installation Guide / 安全指引

The appliance should be installed, connected and tested by qualified electrician, and in accordance with local regulations. 电器应由合格的电工安装、连接和测试，并符合当地法规。

Turn off the power supply before installation or maintenance of the appliance, and make sure that the cables will not be squeezed or damaged by sharp edges. 在安装或维护设备之前，请关闭电源，并确保电缆不会被锋利的边缘挤压或损坏。

在安装或维护设备之前，请关闭电源，并确保电缆不会被锋利的边缘挤压或损坏。

Ensure that LED lighting fixtures do not come into contact with corrosive chemicals, solvents, or abrasive cleaners. 确保 LED 灯具不会接触到腐蚀性化学物质、溶剂或研磨清洁剂等。

确保 LED 灯具不会接触到腐蚀性化学物质、溶剂或研磨清洁剂等。

To avoid injury or damage to the lighting fixtures, please ensure that the power cord and lighting fixtures are securely installed before connecting the power supply. 为避免受伤或损坏灯具，请在连接电源前确保电源线和灯具安装牢固。

为避免受伤或损坏灯具，请在连接电源前确保电源线和灯具安装牢固。

WARNING / 警告

LED lighting fixtures are low voltage distribution. Before connecting the 220V power supply, please ensure that the device is correctly connected to the driver. Otherwise, it will damage the equipment. After activation, hot swapping is not allowed in the drive. LED 灯具为低压配电。在连接 220V 电源之前，请确保设备已正确连接到驱动器。否则，会损坏设备。开启后，驱动器中不允许热插拔。

LED 灯具为低压配电。在连接 220V 电源之前，请确保设备已正确连接到驱动器。否则，会损坏设备。开启后，驱动器中不允许热插拔。

Before any maintenance, adjustment, or cleaning of the lighting fixtures, always ensure that the power is turned off and the LED fixtures have cooled down. Electrical appliances can be cleaned with a soft cloth and standard pH neutral detergent. 在对灯具进行任何维护、调整或清洁之前，始终确保电源已关闭，LED 灯具已冷却。可用软布和标准 PH 中性洗涤剂清洁电器。

在对灯具进行任何维护、调整或清洁之前，始终确保电源已关闭，LED 灯具已冷却。可用软布和标准 PH 中性洗涤剂清洁电器。

Electrical appliances should not be covered with insulation blankets or similar materials. Otherwise, it is easy to cause fire accidents. 电器不应被隔热毯或类似材料覆盖。否则易造成火灾故障。

电器不应被隔热毯或类似材料覆盖。否则易造成火灾故障。

1 Testing products and accessories.
检测产品及配件。

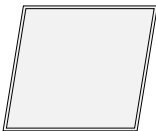

- X 4** Screws
- X 4** Nut
- X 4** Screws
- X 4** Bolt
- X 4** Suspension

2 The long nut is fixed on the wall.
长螺母固定在墙上。

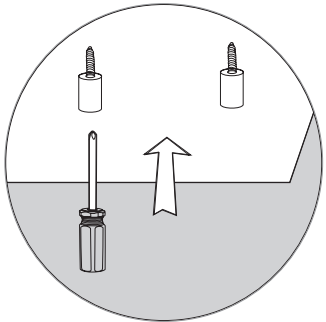

3 Connect the long bolt and wire to the long nut.
长螺栓，电线连接到长螺母上。

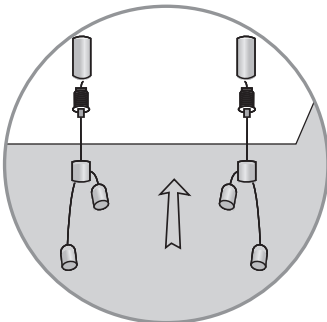

4 Short nut, short bolt for line connection.
短螺母，线路连接短螺栓。

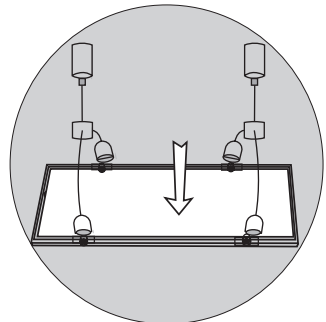

Installation instructions

安装说明书

Suitable for use with similar products / 适于用同类产品

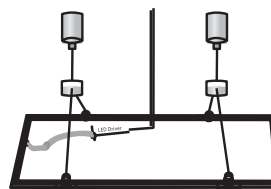

Panel lights / 面板灯

- 5
- The distance between the bolt and the frame is 10cm.
- 螺栓与框架之间的距离为 10cm。

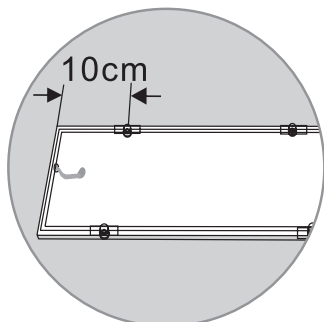

- 6
- After adjusting the balance, it can be connected to the power cord and AC circuit.
- 调整平衡后可以连接到电源线和交流电路。

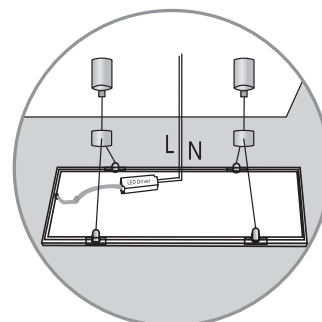

- 7
- Check the wiring and ensure that the installation of the lighting fixtures is secure. If there are no errors, power can be turned on.
- 检查线路，灯具安装是否牢固，无误即可通电。

